

User's Manual

RG Series

Models:

RG25U

RG51UA

Minarik Corp.

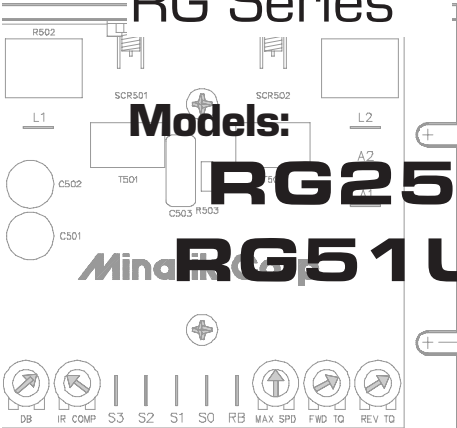

**SCR, Adjustable-Speed
Regenerative Drives
for DC Brush Motors**

Copyright © 1998 by
Minarik Corporation

All rights reserved. No part of this manual may be reproduced or transmitted in any form without written permission from Minarik Corporation. The information and technical data in this manual are subject to change without notice. Minarik Corporation and its Divisions make no warranty of any kind with respect to this material, including, but not limited to, the implied warranties of its merchantability and fitness for a given purpose. Minarik Corporation and its Divisions assume no responsibility for any errors that may appear in this manual and make no commitment to update or to keep current the information in this manual.

Printed in the United States of America.

Safety Warnings

- This symbol  denotes an important safety tip or warning. Please read these sections carefully prior to performing any of the instructions contained in that section.
- Have a qualified electrical maintenance technician install, adjust and service this equipment. Follow the National Electrical Code and all other applicable electrical and safety codes, including the provisions of the Occupational Safety and Health Act (OSHA), when installing equipment.
- Reduce the chance of an electrical fire, shock, or explosion by proper grounding, over-current protection, thermal protection, and enclosure. Follow sound maintenance procedures.
- **It is possible for a drive to run at full speed as a result of a component failure.** Please ensure that a master switch has been placed in the AC line to stop the drive in an emergency.
- **This drive is isolated from earth ground.** Circuit potentials are at 115 VAC above earth ground. Avoid direct contact with the printed circuit board or with circuit elements to prevent the risk of serious injury or fatality. Use a non-metallic screwdriver for adjusting the calibration trimpots.

Contents

Specifications	1
Dimensions	2
Regenerative Drives	4
Installation	6
Mounting drives	6
Line fusing	7
Screw terminal block	8
Spade lugs	8
Speed adjust potentiometer installation	9
RG25U Connections	10
AC line and motor connections	10
Speed adjust potentiometer connections	11
RG51UA Connections	12
AC line, motor, and field connections	12
Speed adjust potentiometer connections	13
Block Diagram	14
Operation	16
Before applying power	16
Startup	16
Line starting and line stopping	16
Automatic restart upon power restoration	17
Regenerative deceleration (RG25U)	17
Regenerative deceleration (RG51UA)	18
Warning	18

Calibration	19
MAX SPD19
FWD TQ19
REV TQ20
IR COMP20
DB22
Application Notes	23
RG25U/RG51UA Connections to other Minarik devices23
Optional speed adjust potentiometer connections24
Troubleshooting	29
Replacement Parts	32
CE Compliance for RG51UA	33
Limited Warranty	inside back cover

Illustrations

Fig	Description	Page
1.	RG25U Dimensions	2
2.	RG51UA Dimensions	3
3.	Four-Quadrant Operation	5
4.	Screw Terminal Block	8
5.	Speed Adjust Potentiometer Installation	9
6.	RG25U AC Line and Motor Connections	10
7a.	RG25U Connection for Unidirectional Operation	11
7b.	RG25U Connection for Bidirectional Operation	11
8.	RG51UA AC Line, Motor and Field Connections	12
9a.	RG51UA Connection for Unidirectional Operation	13
9b.	RG51UA Connection for Bidirectional Operation	13
10.	RG25U/RG51UA Series Block Diagram	14
11.	RG25U Regenerative Deceleration Switch	17
12.	RG51UA Regenerative Deceleration Switch	18
13.	Typical FWD TQ, REV TQ and IR COMP Settings	21
14.	Deadband Settings	22
15.	RG25U/RG51UA Connection to Other Minarik Devices	23
16.	Forward-Reverse Switch	24
17.	Forward-Stop-Reverse Switch	25
18.	Independent Adjustable Speeds	26
19.	Independent Forward and Reverse Speeds	27
20.	Independent Forward and Reverse Speeds with FWD-STOP-REV Switch	28

Tables

Fig	Description	Page
1.	Line Fusing for RG Series Drives	7
2.	Replacement Parts	32
3.	AC Line Filters	34
4.	Armature Filters	35

Specifications

Model	Max. Armature Current (Amps DC)	HP Range with 115 VAC Applied
RG25U	5.0	1/8–1/2
RG51UA	5.0	1/8–1/2
AC Line Voltage	115 VAC, $\pm 10\%$, 50/60 Hz, single phase	
Peak Current Limit	9 ADC	
Maximum Armature Voltage Range at 115 VAC Input	60–75 VDC	
Form Factor	1.77 at base speed	
Acceleration Time (with load)	1 second	
Deceleration Time (with load)	1 second	
Speed Adjust Potentiometer	50K Ω	
Analog Input Voltage Range (isolated; S1 to S2)	0–10 VDC	
Input Impedance (S0 to S2) RG25U	200K Ω	
RG51UA	100K Ω	
Load Regulation at Base Speed	3%	
Speed Range	50:1	
Weight - RG25U	.50 lb (227 grams)	
Weight - RG51UA	.75 lb (340 grams)	
Ambient Temperature Range	10°C–55°C	
Vibration	0.5g max (0 – 50 Hz) 0.1g max (above 50 Hz)	

RG51UA ONLY

Field Voltage (F1 to F2)	100 VDC
Maximum Field Current	1 ADC

Dimensions

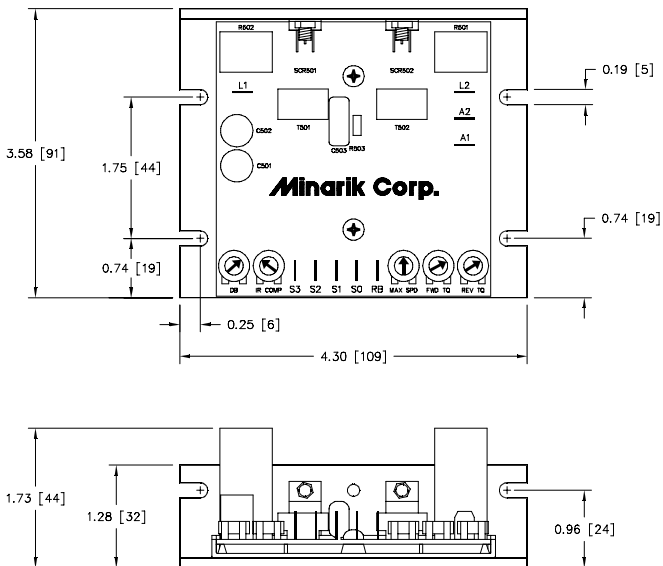

ALL DIMENSIONS IN INCHES [MILLIMETERS]

Figure 1. RG25U Dimensions

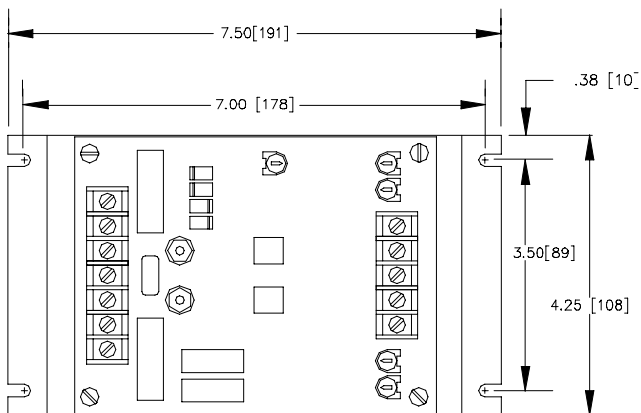

MOUNTING SLOT (4) 0.19 [5] WIDE

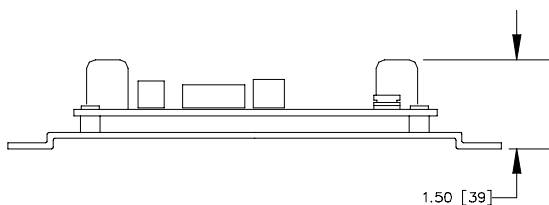

ALL DIMENSIONS IN INCHES [MILLIMETERS]

Figure 2. RG51UA Dimensions

Regenerative Drives

Most non-regenerative, variable speed, DC drives control current flow to a motor in one direction. The direction of current flow is the same direction as the motor rotation. Non-regenerative drives operate in Quadrant 1, and also in Quadrant 3 if the drive is reversible (Figure 3). Motors must stop before reversing direction. Unless dynamic braking is used, non-regenerative drives cannot oppose an overhauling load, and cannot decelerate a load faster than coasting to a lower speed.

Regenerative drives operate in two additional quadrants: Quadrant 2 and Quadrant 4. In these quadrants, motor torque is in the opposite direction of motor rotation.

Regenerative drives can reverse a motor without contactors, switches, brake resistors, and inhibit plugs. They can also control an overhauling load and decelerate a load faster than it would take to coast to a lower speed.

The RG25U and the RG51UA are regenerative drives. They are uncased chassis model drives and designed to be installed in original equipment. The drives are the same electrically. The physical layout and size of these drives are different (see Dimensions section). The RG51UA includes a field supply for shunt wound motors.

The RG25U and the RG51UA are half wave rectified DC regenerative drives. Therefore the maximum armature voltage

of these drives is 75 VDC. This means that a 90 VDC motor will only run at about 83% of rated nameplate speed.

The form factor of the RG25U and the RG51UA is 1.77. This will cause a higher-than-normal heating in the motor armature. To prevent a shorter-than-normal motor life, Minarik recommends that the horsepower rating of the motor for a given application be at least **50%** greater than the required horsepower.

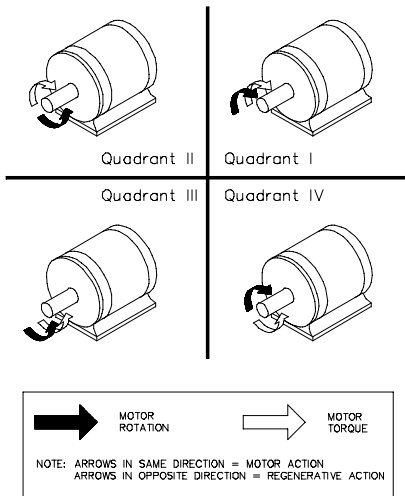

Figure 3. Four Quadrant Operation

Installation

ASSUMPTIONS: Minarik drives supply motor voltage from A1 (or A+) and A2 (or A-) terminals. It is assumed throughout this manual that, when A1 (or A+) is positive with respect to A2 (or A-), the motor will rotate clockwise (CW) while looking at the output shaft protruding from the front of the motor. If this is opposite of the desired rotation, simply reverse the wiring of A1 (or A+) and A2 (or A-) with each other.

Mounting drives

Drive components are sensitive to electrostatic fields. Avoid contact with the circuit board directly. Hold the drive by the chassis only.

Protect the drive from dirt, moisture, and accidental contact. Provide sufficient room for access to the terminal block and calibration trimpots.

Mount the drive away from other heat sources. Operate the drive within the specified ambient operating temperature range.

Prevent loose connections by avoiding excessive vibration of the drive.

Mount the drive with its board in either a horizontal or vertical plane. The RG25U has six 0.188 inch (4.8 mm) wide slots in the chassis that accept #8 pan head screws. Fasten either the large base or the narrow flange of the chassis to the subplate. The RG51UA has four 0.188 inch (4.8mm) wide slots in the base of the chassis that accept #8 pan head screws.

The chassis must be earth grounded for noise suppression. To ground the RG51UA chassis, connect earth ground to the GND terminal on the seven position terminal block.

To ground the RG25U use a star washer beneath the head of at least one of the mounting screws to penetrate the anodized chassis surface and to reach bare metal.

Line fusing

The National Electrical Code requires the installation of a circuit breaker or fuse on the incoming AC line voltage. Use a circuit breaker or fast acting fuse rated for 8 amps or less. With an 115VAC line voltage fuse the hot leg of the AC line that connects to L1 and leave L2 unfused. Use 250VAC fuses. See Table 1 for recommended line fuse sizes.

Table 1. Recommended Line Fuse Sizes

90 VDC Motor HP	Maximum Armature Current	Fuse Rating
1/8	1.5	3
1/4	2.6	5
1/3	3.5	8
1/2	5.0	8

Screw terminal block

Connections to RG51UA drives are made to a screw terminal block (Figure 4). Using a screwdriver, turn the terminal block screw counter-clockwise to open the wire clamp. Turn the terminal block screw clockwise to clamp the wire.

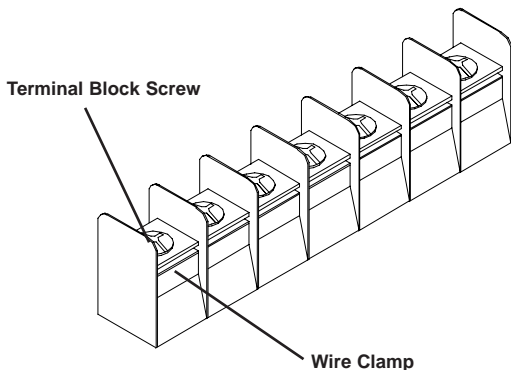

Figure 4. Screw Terminal Block

Spade lugs

Connections to the RG25U are made to .25 inch (.6 mm) spade lugs on the drive.

Speed adjust potentiometer installation

Install the circular insulating disk between the panel and the 50K ohm speed adjust potentiometer. Mount the speed adjust potentiometer through a 0.38 inch (0.96 cm) hole with the hardware provided (Figure 5). Twist the speed adjust potentiometer wire to avoid drawing unwanted electrical noise. If potentiometer leads are longer than 18 inches (46 cm.), use shielded cable.

Warning

Be sure that the potentiometer tabs do not make contact with the potentiometer enclosure. Grounding the input will cause damage to the drive.

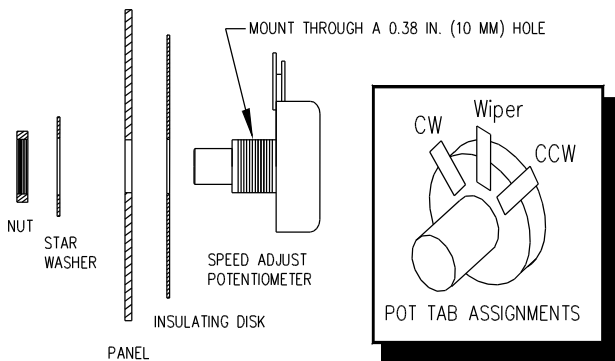

Figure 5. Speed Adjust Potentiometer

RG25U Connections

AC line and motor connections

Use 14 AWG or 16 AWG standard wire for connecting the line and the armature. When connecting the line, standards require installation of a fuse. See page 7 for the details on fuse sizing.

The RG25UA does not have a field output.

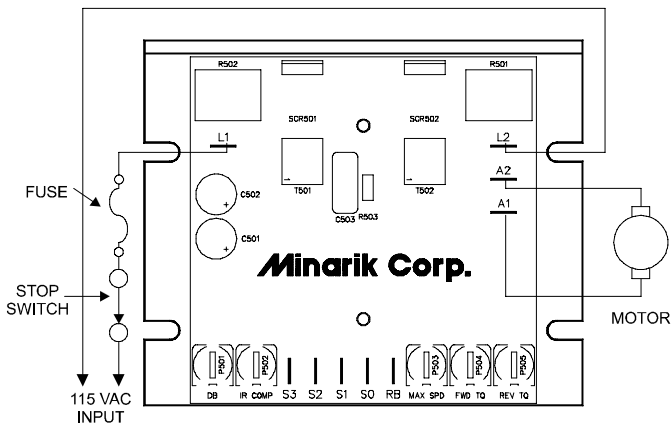

Figure 6. RG25U AC Line and Motor Connections

Speed adjust potentiometer connections

The motor can operate in one direction (unidirectional) or in two directions (bidirectional) depending on how the speed adjust potentiometer is connected to the drive.

Connect the speed adjust potentiometer as shown in Figure 7(a) for speed control in one direction.

Connect the speed adjust potentiometer as shown in Figure 7(b) for speed control in two directions. The motor does not rotate when the wiper is in the center position. Turning the wiper CW from the center position causes the motor to rotate in one direction, while turning the wiper CCW from the center position causes the motor to rotate in the opposite direction.

Refer to the Application Notes section (page 23) for additional speed adjust potentiometer connections.

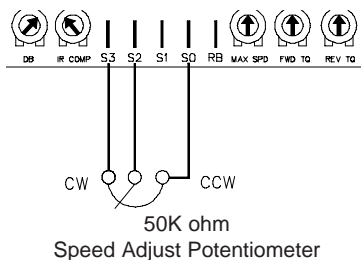

Figure 7a.
Unidirectional Operation

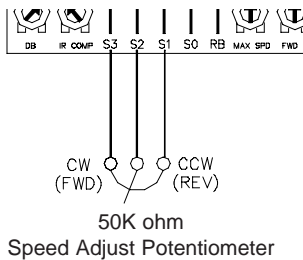

Figure 7b.
Bidirectional Operation

RG51UA Connections

AC line, motor and field connections

The motor and AC line connections to the RG51UA are made to the 7 screw terminal block. Use 14 AWG or 16 AWG standard wire for connecting the line and the armature. Strip the wire insulation 0.25 inches (6 mm).

The field output is for shunt wound motors only.

Do not make any connections to F1 and F2 when using a permanent magnet motor.

The field output connection for the RG51UA is made to the 7 screw terminal block. Use 16 or 18 AWG wire to connect the field output to a shunt wound motor. See Figure 8 for RG51UA connections.

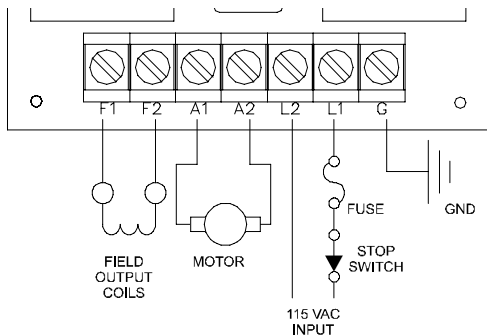

Figure 8. RG51UA AC Line, Motor and Field Connections

Speed adjust potentiometer connections

The motor can operate in one direction (unidirectional) or in two directions (bidirectional) depending on how the speed adjust potentiometer is connected to the drive. Speed adjust potentiometer connections are made to the 5 screw terminal block.

Connect the speed adjust potentiometer as shown in Figure 9(a) for speed control in one direction.

Connect the speed adjust potentiometer as shown in Figure 9(b) for speed control in two directions. The motor does not rotate when the wiper is in the center position. Turning the wiper CW from the center position causes the motor to rotate in one direction, while turning the wiper CCW from the center position causes the motor to rotate in the opposite direction.

Refer to the Application Notes section for additional speed adjust potentiometer connections.

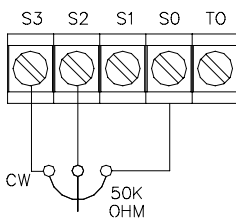

Figure 9a.
Unidirectional Operation

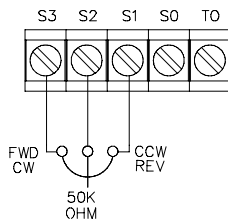

Figure 9b.
Bidirectional Operation

Block Diagram

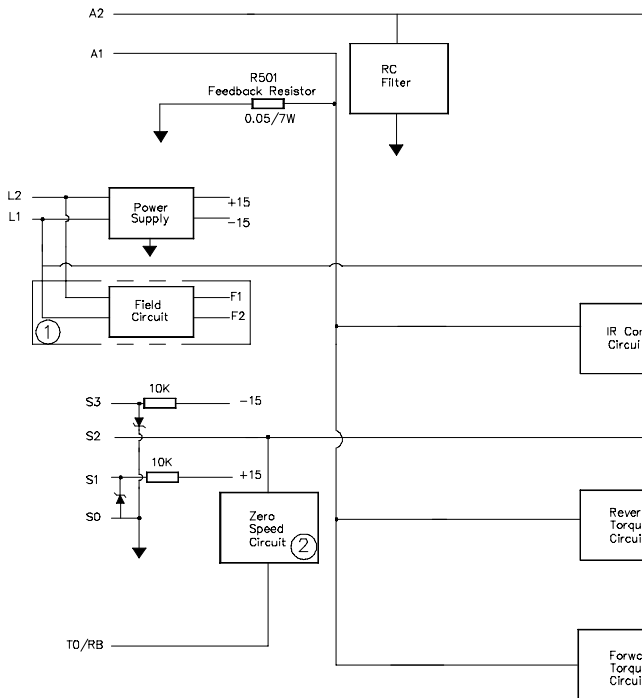
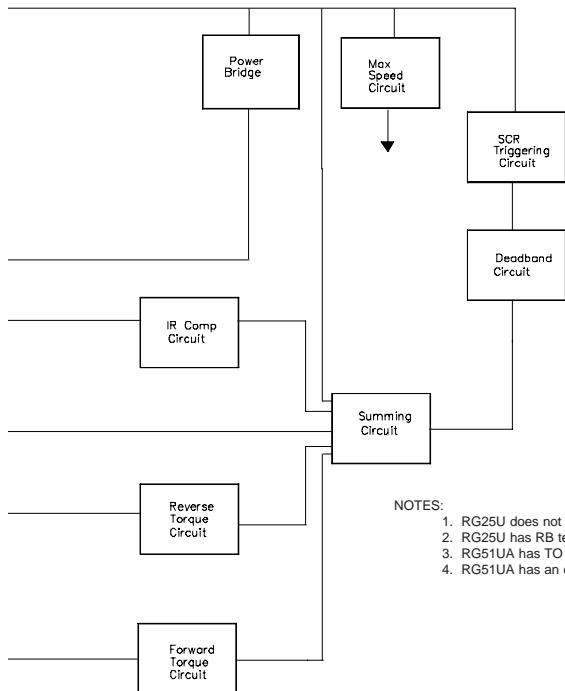

Figure 10. RG25U/RG51UA Series Block Diagram



Operation

Before applying power

1. Check connections before applying AC line voltage to the drive.
2. Check that no conductive material is present on the printed circuit board.

Startup

1. Set the speed adjust potentiometer for zero speed. This may be the center position of the potentiometer if the drive is wired for bidirectional operation or fully counterclockwise if the drive is wired for unidirectional operation.
2. Apply AC line voltage.
3. Slowly advance the speed adjust potentiometer clockwise (CW). The motor slowly accelerates as the potentiometer is turned CW. Continue until the desired speed is reached. If the potentiometer is wired for bidirectional control, advance the potentiometer in either direction off center and the motor will accelerate as the potentiometer is turned.
4. Remove AC line voltage from the drive to coast the motor to a stop.

Line starting and line stopping

Line starting and line stopping (applying and removing AC line voltage) is not recommended with regenerative drives,

except in emergency conditions: line starting and stopping defeats the 4-quadrant control. When AC line voltage is applied to the drive, the motor accelerates to the speed set by the speed adjust potentiometer. When AC line voltage is removed, the motor coasts to a stop.

Automatic restart upon power restoration

All drives automatically run to set speed when power is applied. Wiring a latching relay into the AC line is one way to prevent automatic restarting following a power outage.

Regenerative deceleration (RG25U)

Short terminals S0 and RB to regeneratively decelerate a motor to a stop (Figure 11). Because there is no deceleration adjustment on this drive, the speed at which the deceleration of the motor takes place will be completely dependent upon load inertia, friction, and the settings of the FWD TQ and REV TQ trim pots. This is the fastest stopping action available.

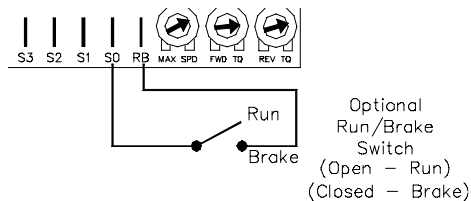

Figure 11. RG25U Regenerative Deceleration
Switch Connection

Regenerative deceleration (R51UA)

Short terminals S0 and T0 to regeneratively decelerate the motor to a stop (Figure 12). Because there is no deceleration adjustment on this drive, the speed at which the deceleration of the motor takes place will be completely dependent upon load inertia, friction and the settings of the FWD TQ and REV TQ trimpots. This is the fastest stopping action available.

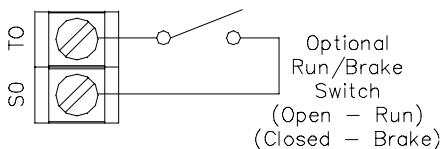

Figure 12. RG51UA Regenerative Deceleration Switch Connection

⚠ Warning

For frequent starts and stops, use regenerative deceleration (shorting RB and S0 on RG25U, or shorting S0 and T0 on RG51UA). Do not use of this method for emergency stopping. They may not stop a drive that is malfunctioning. **Removing AC line power (both L1 and L2) is the only acceptable method for emergency stopping.**

Frequent regenerative deceleration, regenerative braking, produces high torque. This may cause damage to motors, especially gearmotors that are not properly sized for the application.

Calibration

Each drive is factory calibrated to its maximum horsepower rating. Readjust the calibration trimpot settings to accommodate lower horsepower motors.

All adjustments increase with CW rotation, and decrease with CCW rotation. Use a non-metallic screwdriver for calibration. Each trimpot is identified on the printed circuit board.

MAX SPD

The MAX SPD setting determines the maximum motor speed when the speed adjust potentiometer is turned full CW. It is factory set for maximum rated motor speed.

To calibrate, set the speed adjust potentiometer full CW. Adjust the MAX SPD trimpot until the motor turns at the desired maximum speed.

FWD TQ

The FWD TQ setting determines the maximum torque for accelerating and driving the motor in the forward direction. It also sets the maximum torque for decelerating the motor in the reverse direction. FWD TQ is factory set at 120% of rated motor current.

If the time it takes to accelerate a load is too long due to the forward torque setting, increase the forward torque setting to 130% of rated motor current. The decision to change the forward torque setting must be made after considering the gearbox and drivetrain ratings, duty cycle, and motor characteristics. See Figure 13 for typical FWD TQ settings.

REV TQ

The REV TQ setting determines the maximum torque for accelerating and driving the motor in the reverse direction. It also sets the maximum torque for decelerating in the forward direction. REV TQ is factory set at 120% of rated motor current.

If the time it takes to accelerate a load is too long due to the reverse torque setting, increase the reverse torque setting to 130% of rated motor current. The decision to change the reverse torque setting must be made after considering the gearbox and drivetrain ratings, duty cycle, and motor characteristics. See Figure 13 for typical REV TQ settings.

IR COMP

The IR COMP setting determines the degree to which motor speed is held constant as the motor load changes. It is factory set for optimum motor regulation.

Recalibrate the IR COMP setting when using a lower horsepower motor. See Figure 13 for typical IR COMP

settings, or recalibrate using the following procedure:
 If the motor does not maintain set speed as the load changes, gradually rotate the IR COMP trimpot CW. If the motor oscillates (overcompensation), the IR COMP trimpot may be set too high (CW). Turn the IR COMP trimpot CCW until the motor load stabilizes.

RG25U

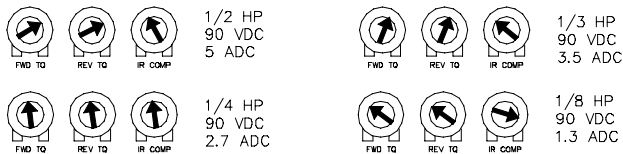

RG51UA

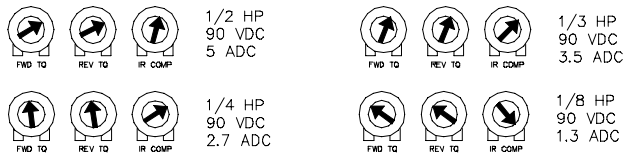

Figure 13. Typical FWD TQ, REV TQ, and IR COMP Settings (actual settings may vary with each application)

DB

The deadband trimmer potentiometer determines the time that will elapse between the application of current in one direction before current is applied in the opposite direction.

The deadband trimmer potentiometer affects the resistance that a motor has to changes in shaft position at zero speed. It does this by applying AC voltage to the motor armature.

Deadband is factory calibrated to approximately the 3 o'clock position for 60 Hz AC line operation. Recalibrate the deadband to the 9 o'clock position for 50 Hz AC line operation. See Figure 14 for recommended deadband settings.

60 Hz
Applications

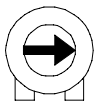

DB

50 Hz
Applications

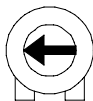

DB

Figure 14. Deadband Settings

Application Notes

RG25U/RG51UA Connections to other Minarik devices

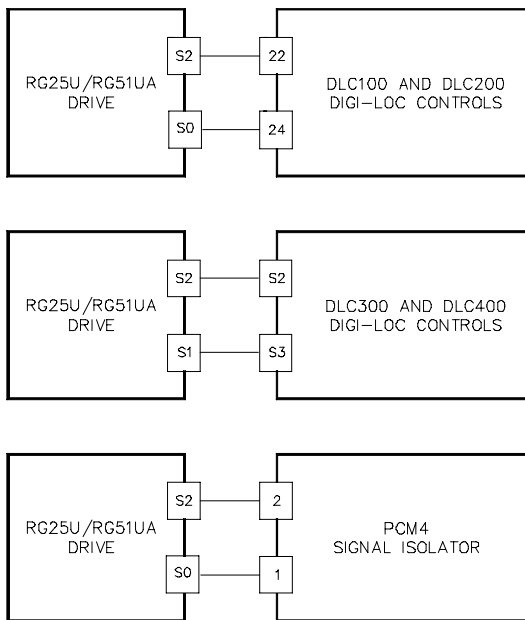

Figure 15. RG25U/RG51UA Connection to DLC100(DLC200), DLC300(DLC400), and PCM4

Optional speed adjust potentiometer connections

Use a single pole, two position switch with a single speed adjust potentiometer to plug reverse the motor (Figure 16). The MIN SPD setting is in effect for either direction.

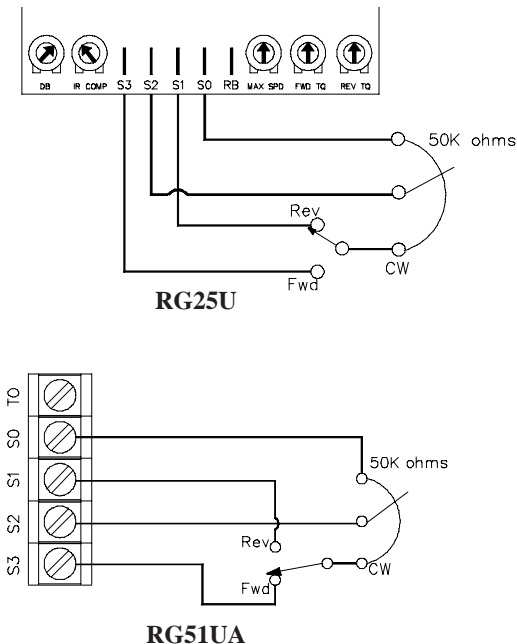

Figure 16. Forward-Reverse Switch

Use a single pole, three position switch with a single speed adjust potentiometer to stop a motor between reversals (Figure 17). Set the switch to the center position to decelerate the motor to a stop.

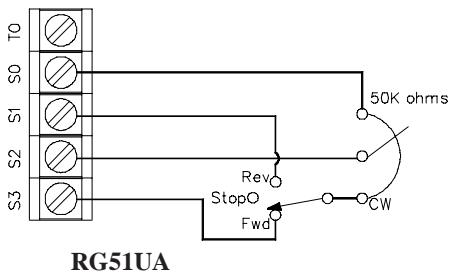
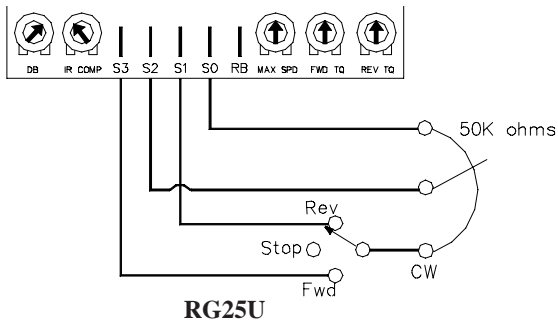

Figure 17. Forward-Stop-Reverse Switch

Connect two speed adjust potentiometers with a single pole two position switch to select between two independent speeds shown in the forward direction (Figure 18). The speed adjust potentiometers can be mounted at two separate operating stations.

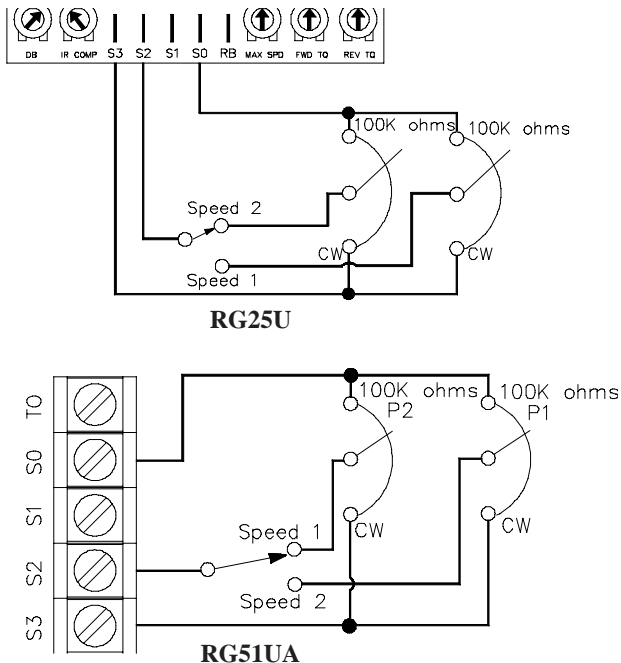

Figure 18. Independent Adjustable Speeds Forward Direction

Connect two speed adjust potentiometers as shown in Figure 19 to select between independent forward and reverse speeds.

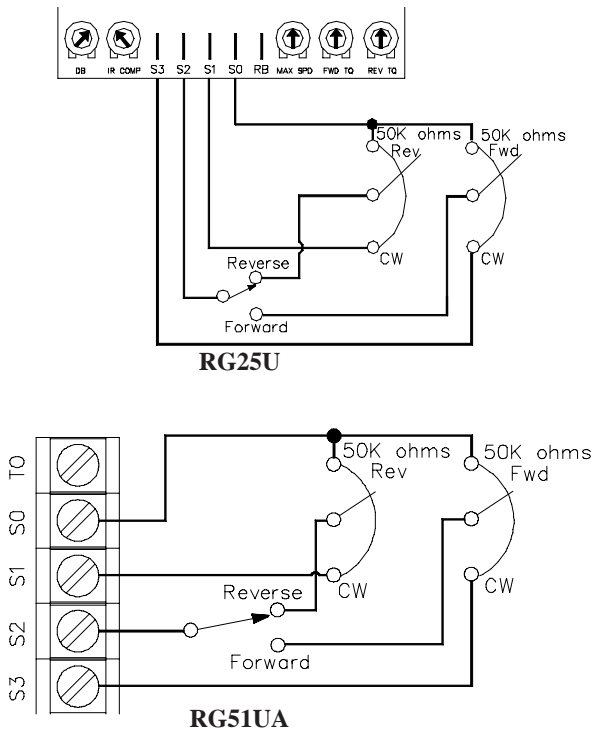
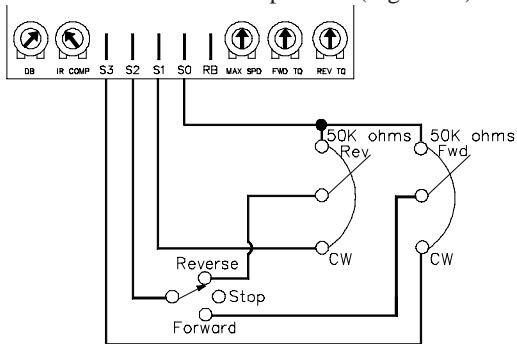
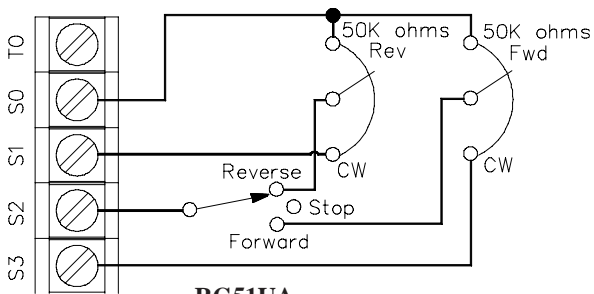

Figure 19. Independent Forward and Reverse Speeds

Use a single pole, three position switch to stop the motor when the switch is in the center position (Figure 20).



RG25U



RG51UA

Figure 20. Independent Forward and Reverse Speeds with a Forward-Stop-Reverse Switch

Troubleshooting

Warning

Dangerous voltages exist on the drive when it is powered. When possible, disconnect the AC line voltage from the drive while troubleshooting. Be alert. High voltages can cause serious or fatal injury.

Before troubleshooting

Perform the following steps before starting any procedure in this section:

- Disconnect AC line voltage from the drive.
- Check the drive closely for damaged components.
- Check that no conductive or other foreign material has become lodged on the printed circuit board.
- Verify that every connection is correct and in good condition.
- Verify that there are no short circuits or grounded connections.
- Check that the drive's rated armature and field outputs are consistent with the motor ratings.

Motor does not run

1. Check for blown fuses or tripped circuit breaker.
2. Verify that the speed adjust potentiometer is not set to zero speed position.
3. Verify that the drive is receiving AC line voltage.
4. Check that the drive is not in current limit. It may be necessary to increase the FWD TQ and REV TQ setting if it is set to a value lower than the current rating of the motor.

Fuses or circuit breaker blows

1. Check all wiring for shorts, grounds, or misconnections.
2. Check that the drive is configured to match the motor rating.
3. Check that the motor is not jammed or restricted from movement.

Motor runs too fast at the maximum speed setting

1. Check that the MAX SPD setting is not set too high.
2. Check that the field output connections (RG51UA only) are secure if you are using a shunt wound motor.

Motor will not stop when the speed adjust potentiometer is set to zero speed

Turn the deadband trimpot CCW until the motor stops.

Motor runs in the opposite direction and speed adjust potentiometer is connected for unidirectional operation

1. Remove AC line voltage.
2. Reverse connections to the motor armature.

Motor slows under load

1. Check that the drive has been correctly calibrated for the motor.
2. Check that the motor is not overloaded.
3. Readjust the IR COMP slightly CW until motor runs at proper speed.

Motor is unstable under load

Readjust the IR COMP setting slightly CCW until motor speed is stabilized.

Motor only runs at full speed

1. Check if the speed adjust potentiometer is open.
2. Check if the connections to for the speed potentiometer are open.

For additional assistance, contact your local Minarik[®] Distributor, or the factory direct: phone (818) 502-1528; fax (818) 502-0716.

Replacement Parts

Replacement parts are available from Minarik Corporation and its distributors for this drive series.

Table 2. Replacement Parts

Model No.	Symbol	Description	Minarik® P/N
RG51UA	R501	0.05Ω, 7 W Resistor	032-0031
	SCR501-502	800 V, 25 A SCR	072-0042
	T505	Transformer	230-0004
		50KΩ Potentiometer Kit	202-0005
		Chassis	223-0188
		7 Screw Terminal Block	160-0019
		5 Screw Terminal Block	160-0060

Model No.	Symbol	Description	Minarik® P/N
RG25U	R501	0.05Ω, 10W Resistor	032-0132
	SCR501-502	800 V, 25 A SCR	072-0042
	T505	Transformer	230-0004
		50KΩ Potentiometer Kit	202-0067
		Chassis	222-0079

Certificate of Compliance

Minarik Corporation hereby certifies that its RG51UA drive has been approved to bear the “CE” mark provided the conditions of approval have been met by the end user.

The RG51UA has been tested to the following test specifications:

**EN55011:1991 (emissions), and
EN50082-1:1992 (immunity)**

Compliance allows the RG51UA to bear the CE mark.

The end user, as described herein, falls into one of two categories:

1. The Consumer will deploy a stand-alone unit as an integral, yet external, portion of the machine being operated.
2. The Original Equipment Manufacturer (OEM) will implement the product as a component of the machine being manufactured.

AC Line Filters

In addition to EMI/RFI safeguards inherent in the RG51UA design, external filtering is required.

Minarik requires the Corcom[®] AC line filters listed in Table 3. Use model 5VR1 with drives rated for 3 ADC or below, and model 20VV1 with drives rated for 10 ADC or below.

Table 3. AC Line Filters

Corcom[®] Model Number	5VR1	20VV1
Rated Current	5 A	20 A
Inductance	1.032 mH	0.88 mH
Capacitance		
Line to Line	0.303 mF	0.303 mF
Line to Ground	0.011 mF	0.011 mF
Discharge Resistor	680 KW	680 KW

Wire the AC line filter within 0.25 meters of the drive. The ground connection from the filter must be wired to solid earth ground (resistance less than 500 ohms), not machine ground. This is very important!

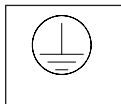

If the end-user is using a CE-approved motor, the correct filter from Table 3 is all that is necessary to meet the EMC directives listed herein.

Armature Filters

If the end-user is not using a CE-approved motor, a second filter on the armature must be deployed. See Table 4 for recommended armature filters. Use model CE04RG with drives rated for 3 ADC or below, and model CE10RG with drives rated for 10 ADC or below.

Table 4. Armature Filters

Minarik® Model Number	CE04RG	CE10RG
Rated Current	4 A	10 A
Inductance	1200 mH	
Capacitance (C1 and C2)	0.1 mF @ 400W VDC	
Discharge Resistor	680KW	

Wire the armature filter to the DC output of the drive, as close to the drive as possible. The ground connection from the filter must be wired to solid earth ground (resistance less than 500 ohms); not machine ground. This is very important!

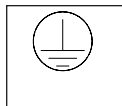

The end user must use the filtration listed in this addendum to comply with CE. The OEM may choose to provide alternative filtering that encompasses the Minarik drive and other electronics within the same panel. The OEM has this liberty because CE is a machinery directive.

Whether or not every component in the OEM's machinery meets CE, the OEM must still submit his machine for CE approval. Thus, no component must necessarily meet CE within the machine, as long as the OEM takes the necessary steps to guarantee the machine does meet CE. By the same token, even if every component in the OEM's machine does meet CE, the machine will not necessarily meet CE as a machine.

Using CE-approved wiring practices (like proper shielding) and the filters should assure the drive will meet EN55014 (1993 emissions standard) and EN50082-1 (1992 immunity standard).

Notes

Notes

Limited Warranty

A. Warranty - Minarik Corporation (referred to as "the Corporation") warrants that its products will be free from defects in workmanship and material for two (2) years or 6,000 hours, whichever comes first, from date of shipment thereof. Within this warranty period, the Corporation will repair or replace such products that are: (1) returned to Minarik Corporation, 901 East Thompson Avenue, Glendale, CA 91201-2011 USA; and, (2) determined by the Corporation to be defective.

This warranty shall not apply to any product that has been subject to misuse, negligence, or accident; or misapplied; or repaired by unauthorized persons; or improperly installed. The Corporation is not responsible for removal, installation, or any other incidental expenses incurred in shipping the product to and from the repair point.

B. Disclaimer - The provisions of Paragraph A are the Corporation's sole obligation and exclude all other warranties of merchantability for use, express or implied. The Corporation further disclaims any responsibility whatsoever to the customer or to any other person for injury to the person or damage or loss of property of value caused by any product that has been subject to misuse, negligence, or accident, or misapplied or modified by unauthorized persons or improperly installed.

C. Limitations of Liability - In the event of any claim for breach of any of the Corporation's obligations, whether express or implied, and particularly of any other claim or breach of warranty contained in Paragraph A, or of any other warranties, express or implied, or claim of liability that might, despite Paragraph B, be decided against the Corporation by lawful authority, the Corporation shall under no circumstances be liable for any consequential damages, losses, or expense arising in connection with the use of, or inability to use, the Corporation's product for any purpose whatsoever.

An adjustment made under warranty does not void the warranty, nor does it imply an extension of the original two (2) year or 6,000 hour warranty period. Products serviced and/or parts replaced on a no-charge basis during the warranty period carry the unexpired portion of the original warranty only.

If for any reason any of the foregoing provisions shall be ineffective, the Corporation's liability for damages arising out of its manufacture or sale of equipment, or use thereof, whether such liability is based on warranty, contract, negligence, strict liability in tort, or otherwise, shall not in any event exceed the full purchase price of such equipment.

Any action against the Corporation based upon any liability or obligation arising hereunder or under any law applicable to the sale of equipment or the use thereof, must be commenced within one year after the cause of such action arises.

Other drives from Minarik Corporation:

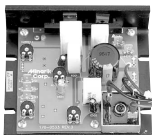

XP Series

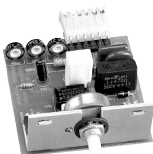

MM3000 Series



MM03-PCM



MM23000 Series

Minarik Automation
& Control

901 East Thompson Avenue
Glendale, California 91201-2011

Phone: (818) 502-1528

Fax: (818) 502-0716

www.minarikcorp.com

Document Number 250-0226, Revision 2

Printed in the U.S.A – 1/98

North America \$10.00, Outside North America \$11.00